

# FÖRST

## TR6 **D** 42

---

Operation & Maintenance Manual

English

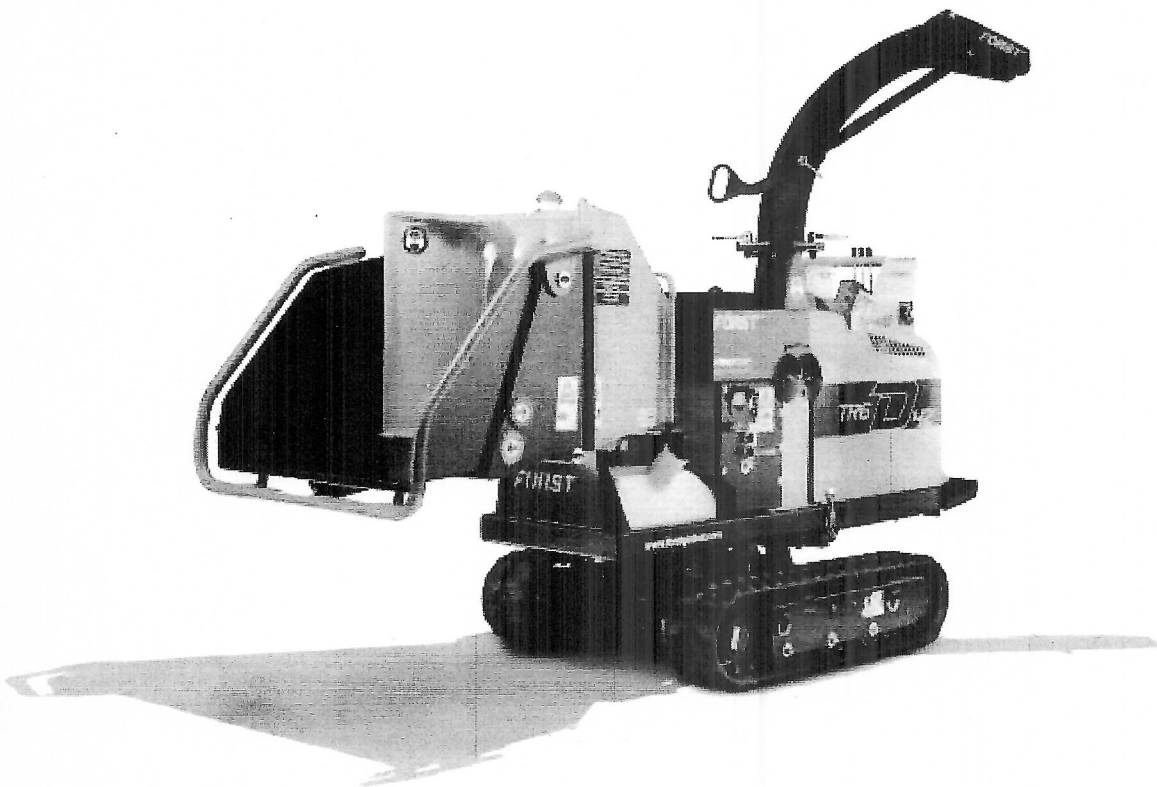

### 1.1 Purpose of Chipper

The Först TR6D is designed to reduce wood material up to 150mm to woodchip. This chipper is capable of processing up to 5 tonnes of wood per hour.

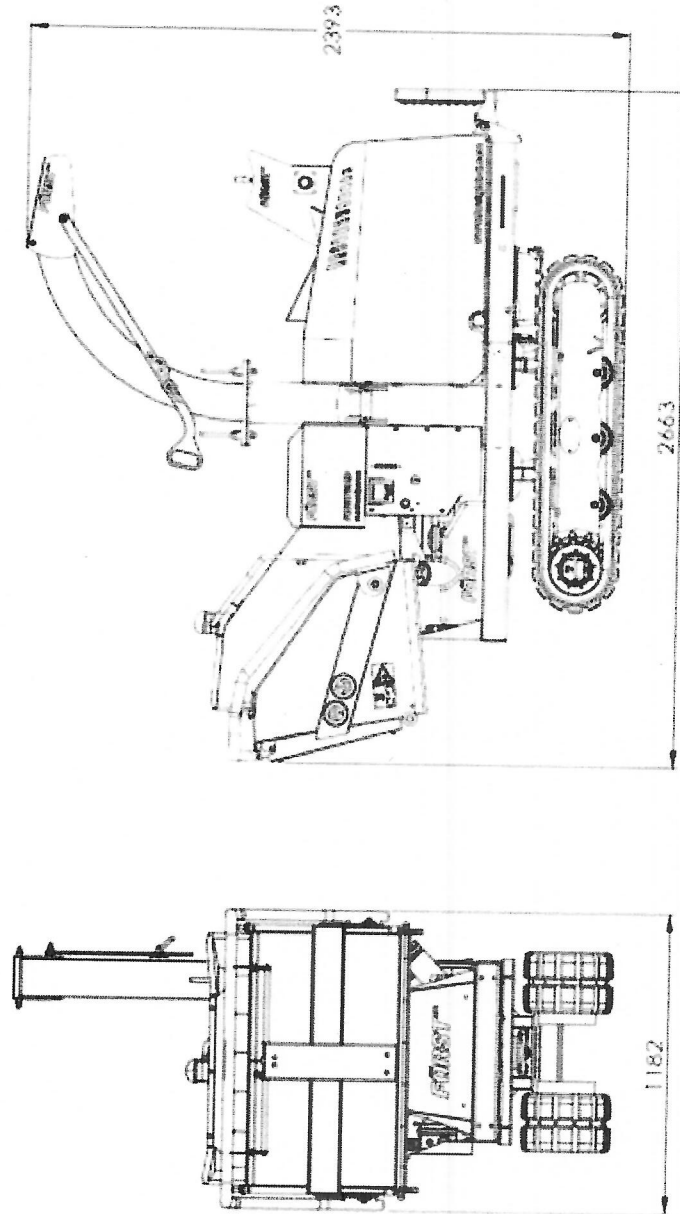

Engine	Doosan D18	Roller Feed	Twin hydraulic motors
Max. power	31kW (42hp)	Max. material diameter	150mm
Cooling	Water Cooled	Fuel Capacity	30 litres
Overall weight	1450kg	Hydraulic Oil Capacity	17 litres
Starting	Electric	Material processing	5 tonnes/hour
		Fuel type	EN590 Diesel

## 1.2 Exterior Components

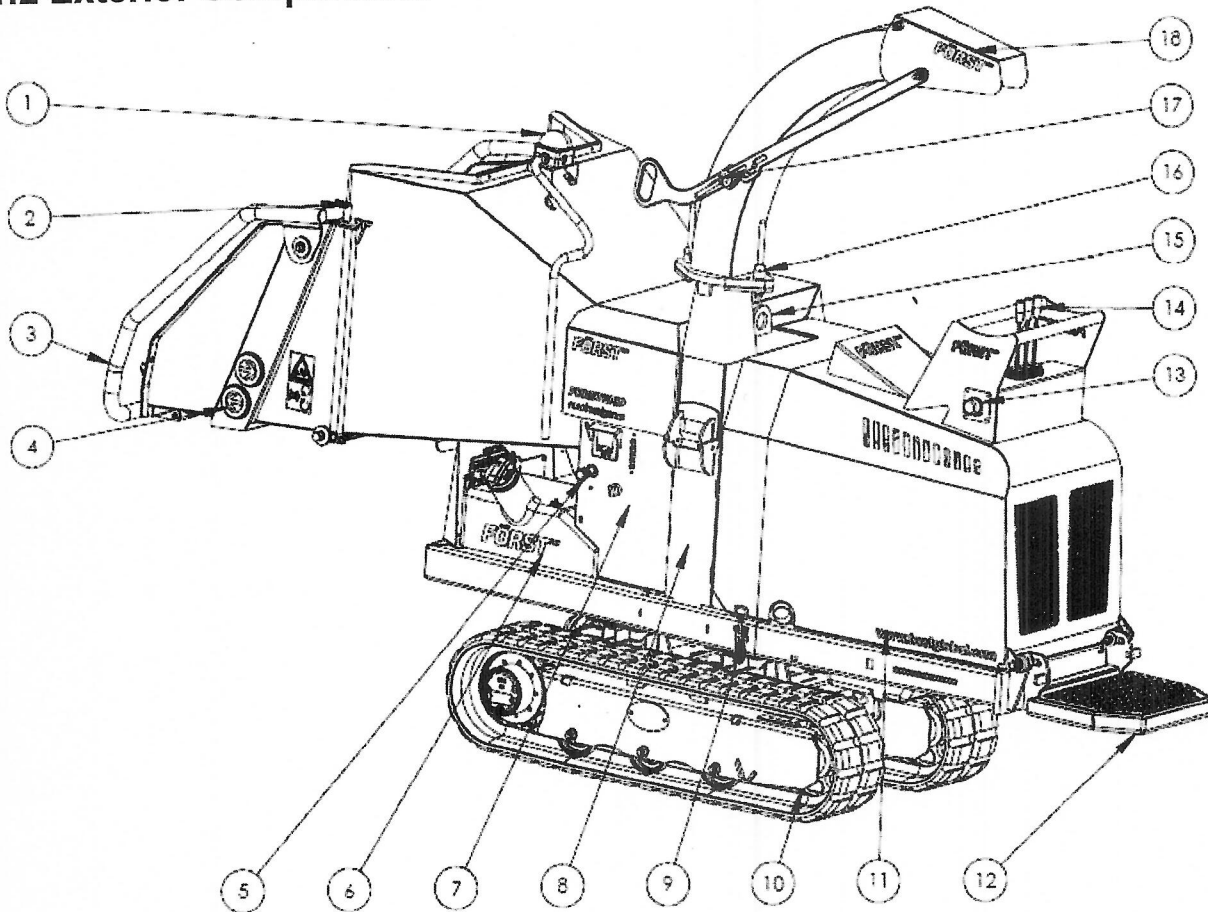

- |                               |                          |
|-------------------------------|--------------------------|
| 1. E-Stop                     | 10. Track base           |
| 2. Hopper tray latch          | 11. Engine cover         |
| 3. Stop bar                   | 12. Footplate            |
| 4. Feed touch sensors         | 13. Throttle             |
| 5. Control valve speed adjust | 14. Control levers       |
| 6. Fuel tank                  | 15. Lifting point        |
| 7. Control panel              | 16. Chute rotation clamp |
| 8. Chipping chamber           | 17. Chute handle clamp   |
| 9. Engine cover latch         | 18. Chute hood           |

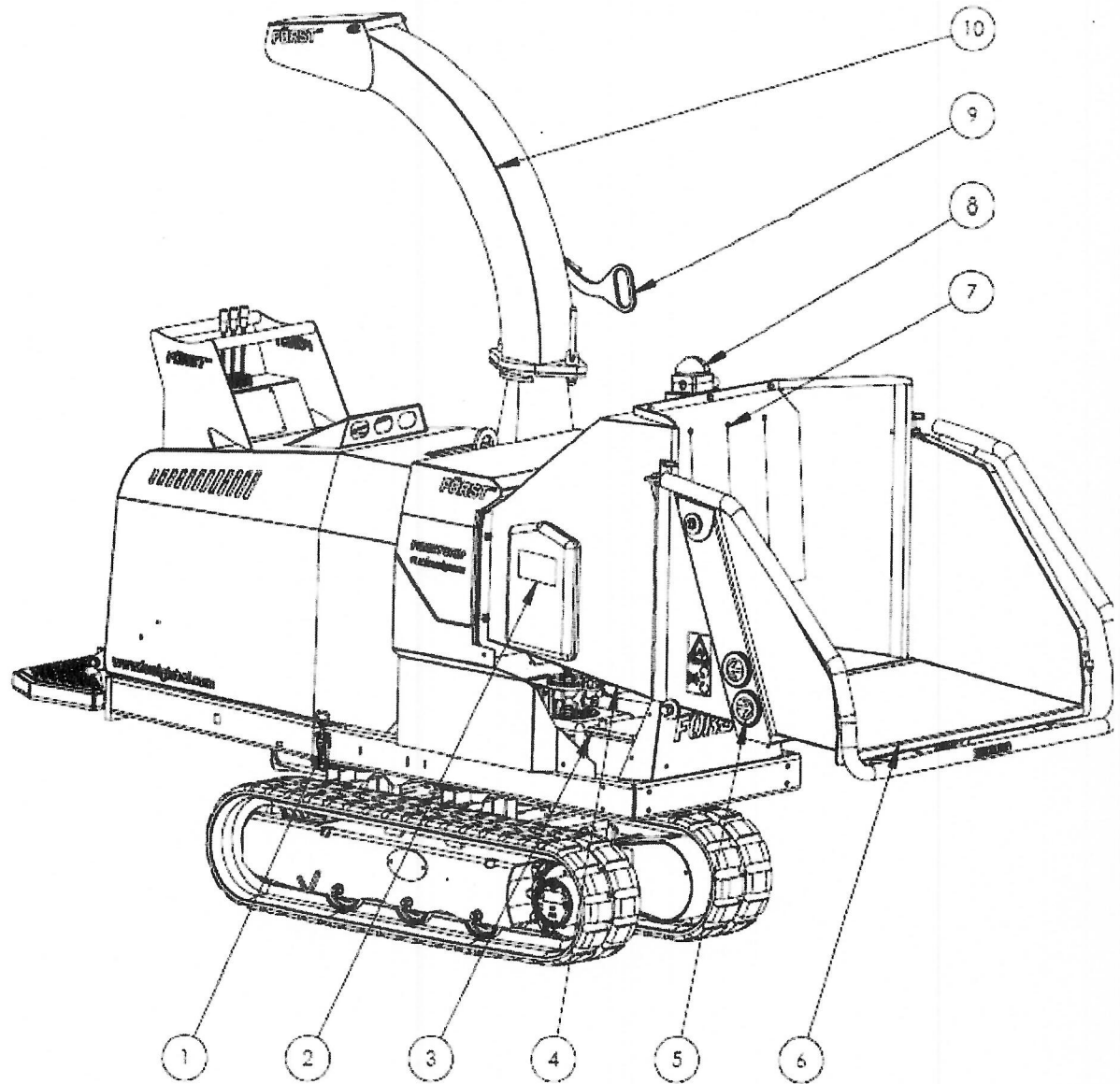

- 1. Engine cover latch
- 2. Document holder
- 3. Battery
- 4. Removable hopper
- 5. Feed touch sensors

- 6. Hopper tray
- 7. E-Stop
- 8. Safety curtain
- 9. Chute handle
- 10. Chute

## 2.0 Safety



### 2.1 Safety Working

Before using this chipper, make sure that you are trained and fluent in its operation. Know the location of and how to use all the safety features. Know how to control the feed and stop the chipper in an emergency. Be familiar with the hazards and safe working practices to prevent injury and damage to property and chipper. Also be aware of the legal restrictions for personnel and towing with vehicles.

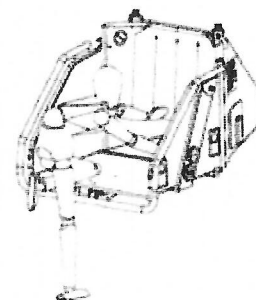
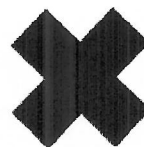
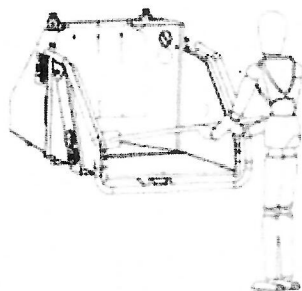
- The minimum age for service personnel is 18 years. Personnel aged 16 can use the chipper for training under supervision by a suitably trained person of 18 years or over.
- Operators and personnel working with this chipper must not be under the influence of alcohol, drugs or medication that would impair judgement, concentration or reaction times. Excessive tiredness is also a risk.
- In use, woodchip and debris are ejected with considerable force from the chute and can travel up to 10m. Make sure the chute directs woodchip to a safe location so that no one can be harmed or property damaged. Do not allow discharge to be directed onto roads or public rights of way.
- Maintain a 10m exclusion zone around the chipper and clearly mark if in a public area. Keep this area free of material build up.
- Make sure the chipper is on even, level and stable ground and cannot move or topple when in use. Use wheel chocks if necessary.
- Keep children and animals well away from the working area.
- The chipper operator must wear protective equipment:
  - Chainsaw safety helmet (EN 397) with mesh visor (EN 1731)
  - Correctly rated ear defenders (EN 352)
  - Work gloves with elasticated wrist bands.
  - Steel toe cap boots (EN345-1)
  - Close fitting heavy duty non-snap clothing. Hi-viz clothing (EN 471) if needed.
  - Protect breathing with a face mask if appropriate. Some plant material can give off harmful dust and poisonous vapours. This may cause respiratory problems or serious poisoning. Check the material to be processed before starting.
- **DO NOT** wear rings, bracelets, watches, jewellery or anything that could be caught on the material being fed and draw you into the chipper.
- All personnel operating or feeding material into the chipper must wear heavy duty non-snap clothing to help prevent being caught on material and drawn into the chipper. The feed mechanism of this chipper uses high powered hydraulic motors to drive sharp toothed rollers that feed material into the cutting blades. **DO NOT** take risks with it. **NEVER ASSIST ANY MATERIAL INTO THE FEED ROLLERS WITH HANDS OR FEET.** Use the wooden paddle or further long material if necessary.
- Never climb onto the hopper area while the chipper is in operation.
- **CAUTION!** – Keep hands and feet outside the hopper. Do not attempt to force material into the chipper by hand – use a piece of wood if necessary.
- Material can be forcibly ejected from the hopper towards the operator. Ensure full head and face protection is worn.
- Very twisted material should be trimmed into manageable pieces. Failure to do this can result in material extending outside the hopper, moving aggressively side-to-side creating a hazard to the operator.
- Do not try to force material over 150mm in diameter into the chipper.
- Carefully site the chipper so operators can work furthest from any local danger. For example, on a road side, place chipper so operators work on the verge and not in the road exposed to traffic

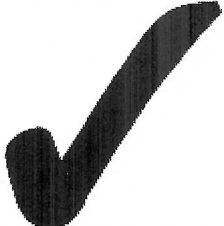

## 2.2 DO's and DON'Ts

											
<ul style="list-style-type: none"> <li>• <b>DO</b> ensure that the starting of the chipper can cause no hazard before starting. i.e. no persons are in the hopper or in any other danger area</li> <li>• <b>DO</b> stop the chipper before making any adjustments, refuelling or cleaning</li> <li>• <b>DO</b> make sure the chipper has stopped rotating and remove the ignition key before any maintenance or the chipper is left unattended. The belts and pulley are to be used to ensure visually that the chipper has stopped rotating</li> <li>• <b>DO</b> ensure that the chipper is level, well supported and cannot move during use</li> <li>• <b>DO</b> run the chipper at full throttle</li> <li>• <b>DO</b> conduct regular chipper checks for visual fluid leaks</li> <li>• <b>DO</b> take regular breaks. Wearing protective equipment can be hot and tiring leading to a lack of concentration, increasing the risk of having an accident</li> <li>• <b>DO</b> keep hands, feet and clothing out of feed area, chute and moving parts</li> <li>• <b>DO</b> always check the <b>all</b> of controls and safety devices (emergency stops, stop bar) <b>before</b> feeding any wood into the chipper</li> <li>• <b>DO</b> remove any additional debris attached to the wood before commencing work i.e. nails, wire, rope etc</li> </ul>	<ul style="list-style-type: none"> <li>• <b>DO NOT</b> use chipper in poor visibility or insufficient light to see clearly</li> <li>• <b>DO NOT</b> use or attempt to start the chipper with discharge chute or guards correctly and secure</li> <li>• <b>DO NOT</b> stand directly in front of the in-feed hopper when using the chipper. Stand to one side</li> <li>• <b>DO NOT</b> allow the following to enter the chipper damage is likely: <table border="1" data-bbox="981 869 1556 1097"> <tbody> <tr> <td>Bricks</td> <td>Metal</td> </tr> <tr> <td>String</td> <td>Glass</td> </tr> <tr> <td>Cloth</td> <td>Rubber</td> </tr> <tr> <td>Plastic</td> <td>Roots</td> </tr> <tr> <td>Stones</td> <td>Bedding Plants</td> </tr> </tbody> </table> </li> <li>• <b>DO NOT</b> stand in front of the chute</li> <li>• <b>DO NOT</b> smoke when refuelling. Petrol fuel is flammable and explosive in certain conditions</li> <li>• <b>DO NOT</b> let anyone who has not received instruction operate the chipper</li> <li>• <b>DO NOT</b> climb on the chipper at any time except tracked chipper ride-on plate where fitted</li> <li>• <b>DO NOT</b> handle material partially engaged in the chipper while in operation</li> <li>• <b>DO NOT</b> touch any exposed wiring whilst the chipper is running</li> <li>• <b>DO NOT</b> restart the chipper immediately if an emergency stop has caused a shut down. Before disengaging the emergency stop a thorough inspection of the chipper should be carried out to ensure the safety conditions are being met</li> </ul>	Bricks	Metal	String	Glass	Cloth	Rubber	Plastic	Roots	Stones	Bedding Plants
Bricks	Metal										
String	Glass										
Cloth	Rubber										
Plastic	Roots										
Stones	Bedding Plants										

## 3.0 Transportation & Storage

### 3.1 Track control and driving

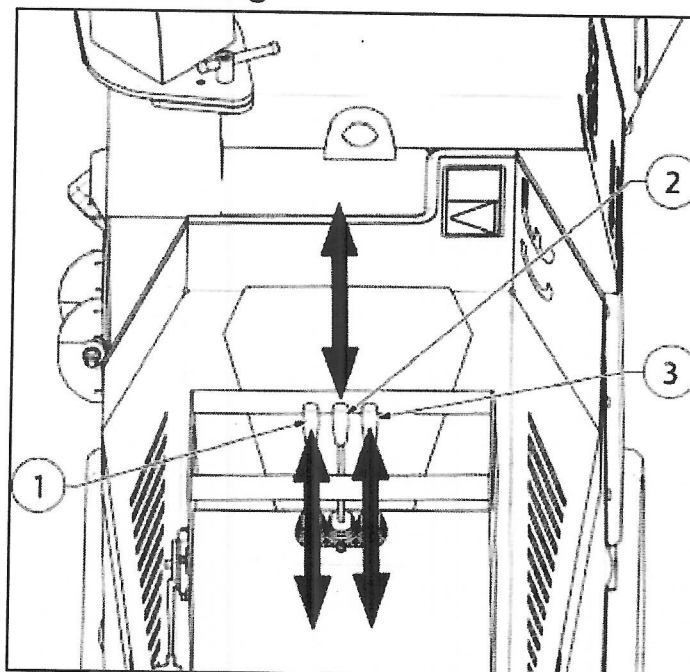

1. Left track forward & reverse
2. Varitrack (optional):
  - Forward – tracks out
  - Backward – tracks in
3. Right track forward & reverse

Driving controls are all situated on the engine cover and operated while at the machine front or standing on the fold down foot plate.

The two outer levers control track rotation direction and speed. When used equally together, this gives forward and reverse and speed increase with greater lever movement. Steering is by using the levers in differing proportions, in opposition or each on their own. Both levers used in extreme opposition will cause the machine to spin on its axis.

Avoid driving on ground too soft to support the machine's weight.

Take great care when driving on inclined ground as there is a risk of the machine toppling. This is most likely when turning or crossing the incline, try to avoid these manoeuvres. Do not drive on ground with an incline in excess of 20°.

Make sure the engine and hydraulic oil are warm before working on inclined ground. If the machine has to be stopped on an incline, make sure that the machine is pointing either up or down the slope. Also chock both tracks at the downhill end.

### 3.2 Transporting the Chipper

- Always carry out loading to and unloading from the transporting vehicle on solid level ground.
- Use a loading ramp of less than 15° that is strong and wide enough to take the machine's weight.
- Make sure the ramp and transporting vehicle bed are clean and free of mud, ice or oil. If slippery, this presents a danger.
- In cold weather, make sure the engine and hydraulic oil are warm before loading/unloading.
- Do not steer the machine while on ramps, this is extremely dangerous. If adjustment has to be made, drive back onto ground or vehicle bed, steer, then negotiate the ramps.
- Drive slowly while loading/unloading and take care when the machine passes over hump at the ramp to bed join.
- Position the machine at the trailer/vehicle bed centre.
- Fasten machine securely to transport vehicle via both lashing eyes on track base front and rear. Use appropriately rated cables, chains or ratchet straps. Make sure that no securing passes over or traps any hydraulic hoses.
- Clear machine of loose woodchip material before departing.
- Ensure the chute is securely fixed at the inboard position before departing.
- Ensure that the hopper tray is closed in the up position and the locking latch is fully engaged before departing.

### 3.3 Care of Rubber Tracks

- Do not manoeuvre on hard, stony and highly abrasive surfaces.
- Do not leave tracks exposed to direct sunlight for more than 3 months.
- Avoid aggressive steering on asphalt and concrete as this will cause excessive track wear. Also avoid driving on asphalt that is hot and above 60°C, it will damage the tracks and asphalt.
- Loose tracks can be detached and damaged when manoeuvring on very uneven ground.
- Tracks are for use on soft ground. They will rapidly deteriorate if used on hard or abrasive surfaces such as sand, stone or minerals.
- Do not let synthetic oils or fuel get onto the track. Clean immediately if this occurs.
- Do not use tracks in a marine or coastal environment as salt and salt air will corrode the steel inner core and track components.



### 3.4 Lifting the Chipper

The lifting eye is designed for securely holding the chipper's weight only. Do not use hoist hook directly on the lifting eye. Use a correctly rated safety shackle. Inspect lifting eye before each use and do not use if damaged.

Ensure the chamber lid bolts are secure and tightened to the correct torque (86 Nm).

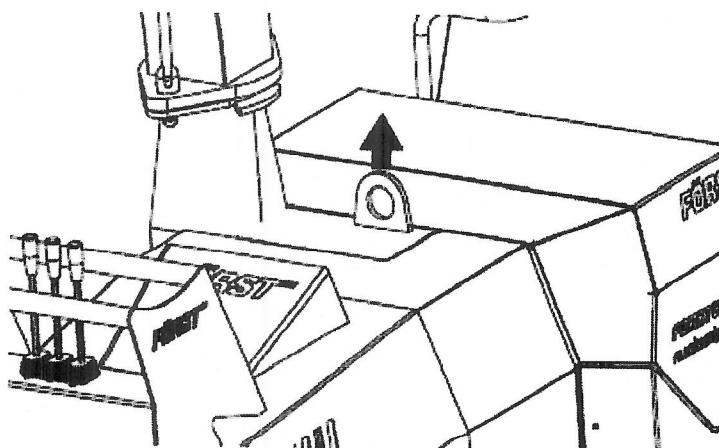

### 3.5 Storage of the Chipper

For safe storage of the chipper, ensure the following points are met:

1. Chipper to be stored on a level, even surface
2. Hopper tray to be in the 'Up' Position

## 4.0 Chipper Operation

1. Fold down hopper tray
2. Start engine
  - a. Turn ignition key to pre-heat
  - b. Wait for display to indicate 'start engine'
  - c. Turn key to crank engine and release once firing
3. Allow engine to run for 30 seconds at idle, then increase revs to full
4. To feed material into chipper, tap the green button once
5. To stop, push the E-Stop button or push the red stop bar
6. To reverse the feed:
  - a. Tap the orange button once for a momentary reverse
  - b. Tap the orange button twice for continuous reverse
7. Stop the machine:
  - a. Touch the E-stop or push the stop bar
  - b. Reduce revs to idle
  - c. Switch off ignition and remove key
8. Before transporting the machine:
  - a. Sweep out debris from hopper
  - b. Close hopper tray using the stop bar and engage the locking pins

## 4.1 Control Panel & Ignition

This chipper is fitted with an engine PLC (Programmable Logic Controller) system that manages the engine, feed and all safety features. The control panel is located on the right-side panel. Feed and engine speed are controlled with a "No Stress" function ensuring that cutting conditions are kept within optimum limits. This maximises throughput while minimising jams and blockages. There will be times when material is being cut and the feed will momentarily stop until engine speed increases. At this point, the feed will start without warning. Service warnings shown below will be displayed at certain intervals. The engine will not start until OK is pressed.

- First 20 Hour Warning: "Change Hydraulic Oil Filter"
- Every 20 Hour Warning: "Blade and Machine check required see manual"
- Every 500 Hour Service Warning: "Full Service recommended"

### 4.1.1 Control Panel

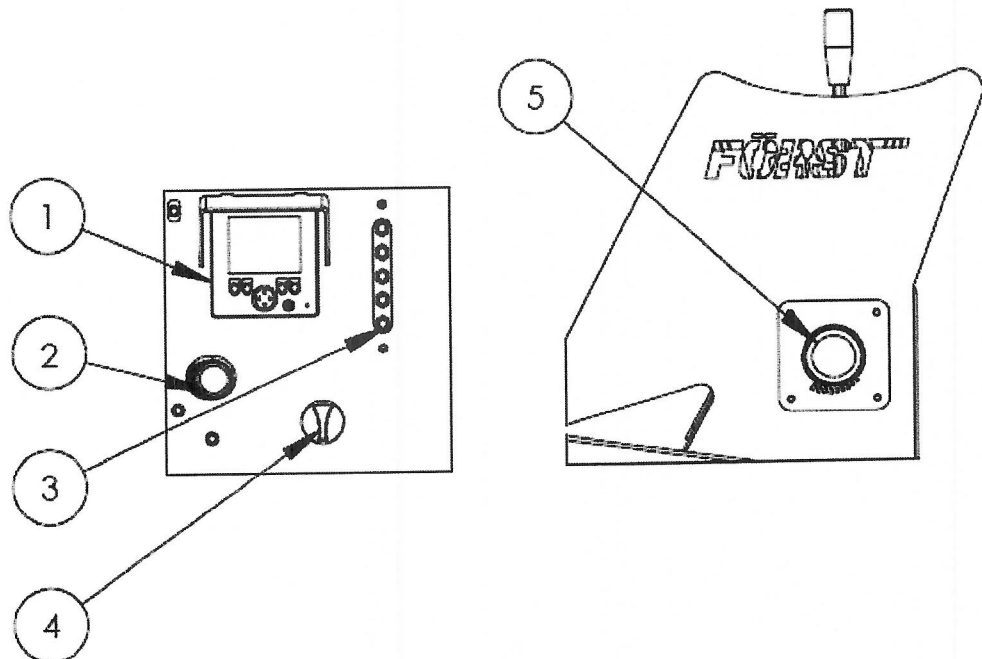

1. Control Panel
2. Ignition

3. Grease bank
4. Throttle

### 4.1.2 Ignition Switch

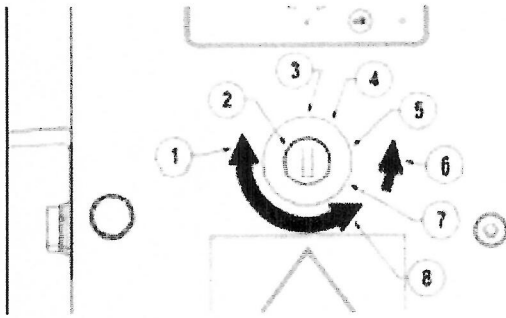

1. Key rotation in switch to start
2. Ignition switch positions & function
3. Off
4. Ignition
5. Pre-Heat
6. Spring biased to pre-heat when released
7. Start
8. Key rotation in switch to stop

Turn ignition key clockwise to first position, then to pre-heat, start display will show, enables pre-heat automatically showing start display + pre-heat.

### 4.1.3 Control Panel



OR with Pre-heat

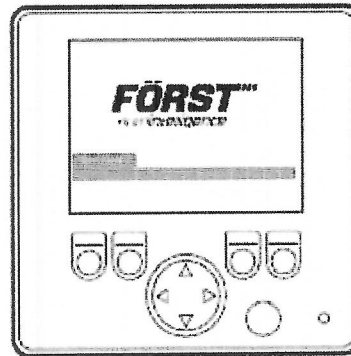

Turn ignition key fully clockwise to crank engine. Display will automatically go to P1



If engine fails to start, turn key to off position and start process again. P1 shows Working Hours and charging indicator text at the screen bottom centre.

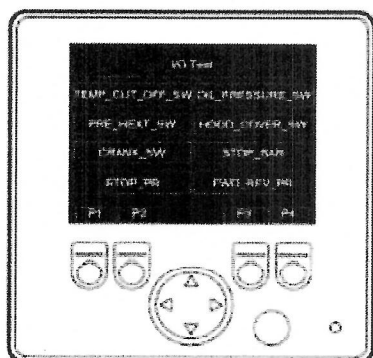

P2 shows I/O tests. Tests all functions and safety controls.

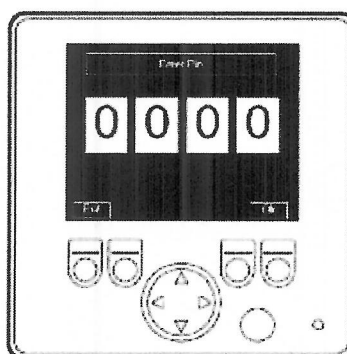
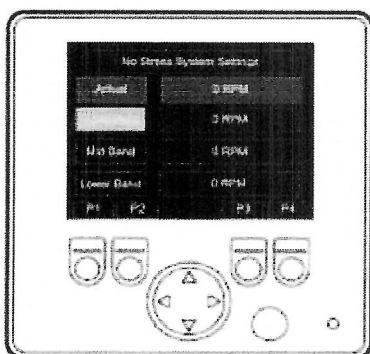

Pin screen

P3 shows No-Stress Settings

- Actual RPM
- Upper Band - 1400 RPM
- Mid Band – 1125 RPM
- Lower Band – 925 RPM
- 

Pin screen automatically displays if any setting changes are attempted.

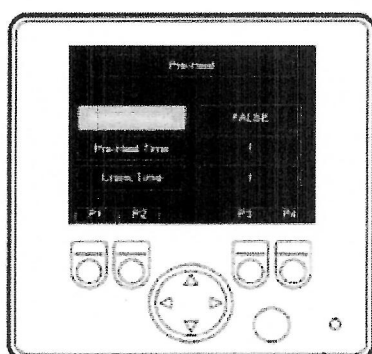

**To stop engine, turn off with ignition key by turning fully anti-clockwise.**

P4 shows Pre-Heat Settings

- Enable Pre-Heat – True
- Pre-Heat Time – 10
- Crank Time – 3

## 4.2 Feed Speed Adjustment

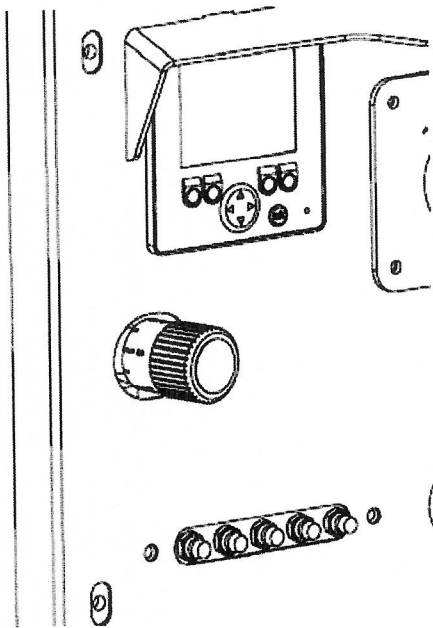

Control valve speed adjustment  
Position indicated by pip

0 = minimum

10 = maximum

The feed speed can be adjusted to suit the material being chipped. Turn dial to align number with pip. Set feed speed so that the No-Stress operates as little as possible, this will give the highest throughput. When feeding Leylandii or leafy material, set feed roller speed to 4.5.

### 4.3 Emergency Stopping

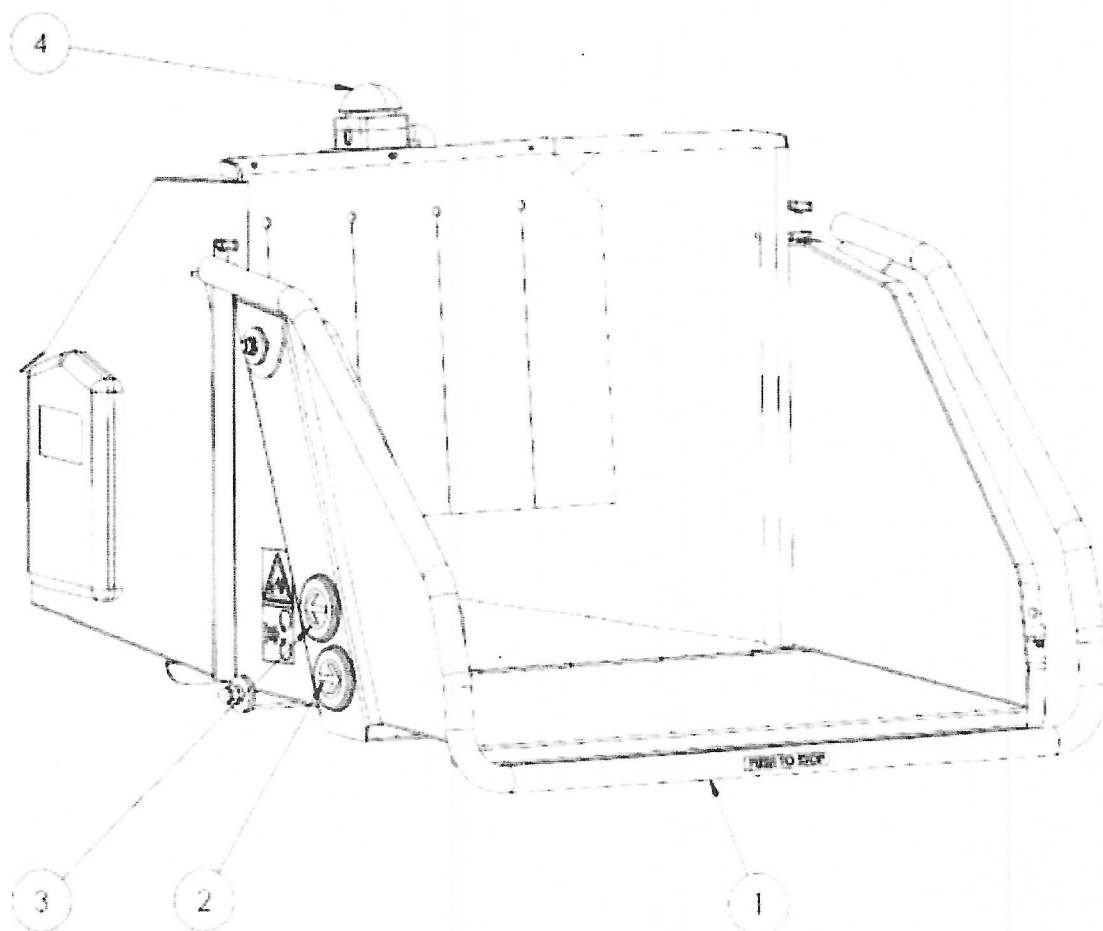

1. Red Stop Bar
2. Orange reverse button
3. Green forward button
4. E-Stop

#### Before using the chipper:

1. Start the machine with the ignition key on the control panel.
2. With the engine running at full speed tap the green button (3) and the rollers will go into forward (chipping mode).
3. Tap the orange button and the rollers will go into a short reverse, tap it again and the rollers will continue in reverse.
4. To stop the feed rollers, push the red stop bar (1) and the rollers will stop instantly and or push the e-stop button and whole machine will shut down.
5. If any of these functions fail, turn off the machine and remove the key from the ignition switch and contact Redwood Global and ask for service.

## 4.4 Feed Jam & Blockages

Be aware that whatever is fed into the machine has to come out of the chute. Always monitor the state of chip flow out of the chute. If it stops, **STOP FEEDING MATERIAL IMMEDIATELY**. Continuing to feed material will further compact a blockage and make it more difficult to clear.

### If the chipping chamber or chute become blocked:

1. Stop the engine and remove ignition key
2. Remove chute and check that it is clear
3. If the chipping chamber is blocked, open the engine cover, then chipping chamber cover. **DO NOT REACH INTO THE CHIPPING CHAMBER WITH HANDS**. Beware that the flywheel within the chipping chamber has two sharp blades mounted on it and can move causing a serious injury risk. Wearing protective gloves and using a piece of wood, carefully clean out the chipping chamber

### If feed becomes jammed:

1. Stop the engine and remove ignition key
2. Open engine and chipping chamber covers
3. Release feed roller spring tension on both sides by slackening off the eye bolt nuts and remove if necessary
4. Insert feed lift tool and lift top feed roller to fully open
5. Insert M12 screw into side of feed chamber and screw completely in. If possible, lower top feed roller onto the screw to secure in the open position. This screw acts as a safety stop once the obstruction has been removed.
6. There should now be access to the feed chamber. Beware that this is the machines cutting zone. The top and bottom feed rollers have sharp teeth and the flywheel cutting blades are not far from them. **DO NOT PUT HANDS INTO THIS AREA**. Wearing protective gloves and using a piece of wood, carefully clear jammed material inside feed chamber
7. When clear, lift top feed roller via lifting tool, remove top feed M12 securing screw, lower top feed roller and remove lifting tool
8. Re-assemble feed tensioner springs and close covers

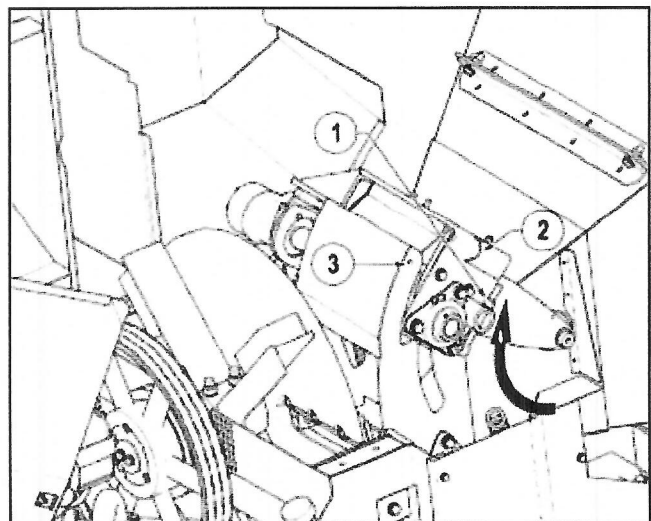

1. Slacken or remove spring tensioner nuts both sides before lifting feed roller
2. Insert top feed roller lifting tool into slot and lift
3. Insert m12 screw to hold feed in open position



## 5.0 Routine Maintenance

The following must be checked at least on a daily basis during use (also see Service schedule):

- Check engine oil
- Check water level in radiator
- Check debris screen on front of radiator and remove any debris
- Check hydraulic oil level. When the machine is new, the oil level may drop during initial use. Regularly check and top-up until level settles. If a top up is required, thoroughly clean around filler cap before removing to help prevent debris falling into oil tank, top up as required and replace filler cap
- Grease machine. Every 8 hours, one pump of grease to each of the six nipples at the central grease point manifold located near the control panel
- Check all fasteners are present and assembled to the correct torque
- Check proximity sensors on engine cover, removable hopper and trip bar are not damaged and working correctly. The trip bar sensor is the most vulnerable and if severely damaged could result in the trip bar not working
- Check drive belt tension and adjust as necessary
- Check pulleys and taper lock on flywheel shaft
- Check flywheel blades for damage and sharpness. Machine performance is adversely affected if blades are blunt or damaged. Replace and sharpen blades as required. Make sure that the blade seat is clean and free of damage before reassembly. Shims are available to adjust for blade size reduction after sharpening. Please refer to blade sharpening for size limits, adjustment shims and setting. Ensure blade fasteners are correctly installed and tightened to the appropriate torque. Check after 1 hours' work then weekly
- Anvil and side anvil are replaceable and double sided. Make sure that the anvil seat is clean and free of damage before reassembly
- Exercise extreme care to avoid injury when removing and replacing blades and anvils. The flywheel can turn creating crush and cutting points in and around the chipping chamber
- Check all hydraulic hoses and fittings after 5 hours' work. Beware of hydraulic oil leaks, they can cause serious injury while the engine is running and the system is under pressure. A leak can easily inject high pressure oil deep into flesh and blood stream requiring immediate medical attention. **DO NOT CHECK FOR LEAKS WHILE THE ENGINE IS RUNNING.** Hoses to the feed roller hydraulic motors are the most likely to become damaged as they are constantly moving during use. If hoses are replaced, all seals must be replaced at the same time. All replacement hoses must be rated to the pressure of the chipper hydraulic system
- Check top and bottom feed motor bracket bolts weekly

## 5.1 Debris Screen

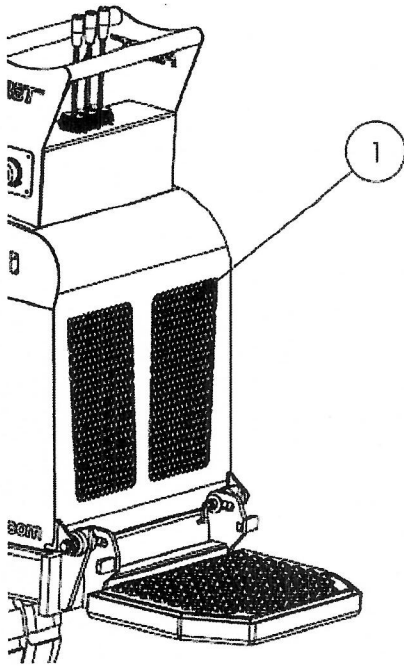

1. Lift the bonnet and brush off any debris from **both** sides of the screen
2. Brush off any debris from the radiator

## 5.2 Engine Maintenance

Please refer to the engine manual supplied with this machine for the following:

- Checking the engine oil.
- Changing the engine oil, oil filter and fuel filter.

## 5.3 Fastener tightening torques

Tightening Torques for class 8.8 and 10.9 fasteners				
	Class 8.8		Class 10.9	
	Nominal Torque (Nm)	Max/Min torque (Nm)	Nominal Torque (Nm)	Max/Min torque (Nm)
<b>M6</b>	10	9.5/10.4	14.5	14/15.3
<b>M8</b>	25	23.1/25.3	35	34/37.2
<b>M10</b>	49	46/51	72	68/75
<b>M12</b>	86	80/87	125	117/128
<b>M16</b>	210	194/214	310	285/314
<b>M20</b>	410	392/431	610	558/615
<b>M24</b>	710	675/743	1050	961/1059

All machine fastener torques should be regularly checked to the above table. In particular, those for the flywheel blades, flywheel bearings, axle assembly, hitch, road wheels and engine mounts.